

# INSTALLING TOGGLE CAM OPERATED APRON CLUTCH

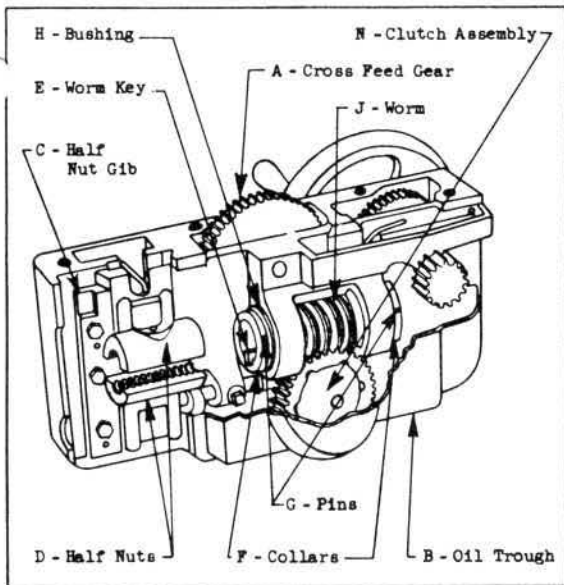

Fig. 1

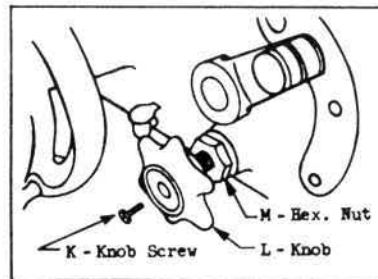

Fig. 2

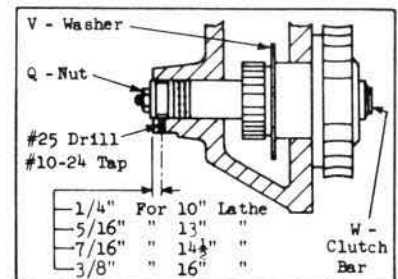

Fig. 3

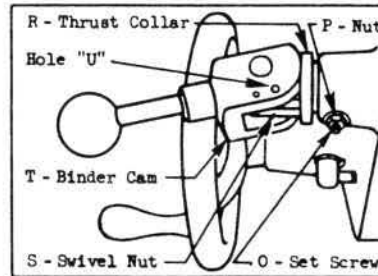

Fig. 4

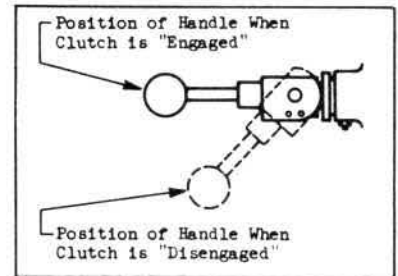

Fig. 5

## TO REMOVE STAR KNOB CLUTCH:

1. Remove drain plug from bottom of apron and drain oil reservoir.
2. Remove saddle lock and bolt.
3. Place support under apron to prevent from dropping and bending lead screw.
4. Remove rear lead screw bracket.
5. Remove screws holding apron to saddle.
6. Loosen the saddle gib screws on the back underside of the saddle, approximately  $\frac{1}{4}$ ".
7. Remove apron from lathe by lifting up on the front of the saddle so the cross feed gear "A" (Fig. 1) in the apron will clear the saddle. Then slide apron off the lead screw at the tailstock end of the lathe but be careful not to bend lead screw.
8. Remove oil trough "B", half nut gib "C", half nuts "D" and key "E" (Fig. 1).
9. Mark the two collars "F" (Fig. 1) so when reassembling they can be replaced in their original position. Then drive out the two pins at "G" and unscrew both collars "F".
10. Remove bushing "H" (Fig. 1) carefully to avoid tearing felt wick. Note how felt wick is wrapped around worm gear. With bushing removed draw wick through hole bored for bushing.
11. Remove apron worm "J".
12. Remove screw "K" (has left hand thread), knob "L" and nut "M" (Fig. 2).
13. Remove clutch assembly "N" (Fig. 1) from back of apron. The oil distributing washer "V" (Fig. 3) on the clutch may have to be positioned to permit removing.

## INSTALLING TOGGLE CAM CLUTCH:

14. Drill and tap hole in bottom of apron hub as shown in Fig. 3, then file bottom of hub flat so nut can be locked against this surface.
15. Install screw "O" and nut "P" (Fig. 4) but do not let screw "O" protrude into bored hole.
16. Position oil distributing washer "V" (Fig. 3) inside apron and insert new clutch assembly (Fig. 3). Apply slight pressure on clutch bar "W" (Fig. 3) and tighten set screw "O" and nut "P" (Fig. 4).

17. Apply pressure on clutch bar "W" (Fig. 3), remove nut "Q" and commercial washers (discard nut and washers). Maintain pressure on clutch bar, install collar "R" and swivel nut "S" (Fig. 4). Screw the swivel nut on tight enough so the handle will lock itself against the thrust collar in the "engaged" position (Fig. 5). It is important to maintain pressure on clutch bar until swivel nut "S" is fastened as allowing it to back up more than  $\frac{3}{32}$ " may cause the outside clutch plate to drop over the clutch sleeve and become distorted when tightened later.
18. Swing handle into a down or "disengaged" position (Fig. 5) and tighten swivel nut "S" (draw up as tight as possible) with Allen head wrench through hole shown at "U" (Fig. 4).
19. Insert worm "J" and thread felt wicking around worm gear and through bored hole. Extra wick provided if original is torn.
20. Replace bushing "H" and insert wick in keyway of bushing.
21. Install collars "F" in their original position and insert pins "G".
22. Turn worm "J" so keyway will be in down position and insert key "E".
23. Replace half nuts "D" and fasten gib "C".
24. Replace gasket and oil trough "B".
25. Turn lead screw so keyway is in down position and mount apron on lathe, checking to see that cross feed gear "A" is in mesh with gear on cross feed screw, again be careful not to bend lead screw.
26. Replace saddle lock screw and saddle lock.
27. Fasten apron to saddle and tighten saddle gib screws.
28. Install rear lead screw bracket.

## POSITIONING CLUTCH LEVER:

29. The clutch lever can be positioned (Fig. 5) by loosening set screw "O" and rotating the complete clutch assembly, then tighten set screw "O" and lock with nut "P". BEFORE TIGHTENING THE SET SCREW, HOWEVER, PULL SLIGHTLY ON THE CLUTCH LEVER ALLOWING THE CLUTCH MECHANISM TO COME FORWARD AS FAR AS POSSIBLE.
30. Replace oil drain plug.

## LUBRICATION:

Fill apron reservoir with proper lubricant (S.B.L.W. Catalog No. 1602 or equal) and oil lead screw bracket.

SERIAL NUMBER OF LATHE AND UNIT CODE NUMBER "MUST" ACCOMPANY ORDER. SEE APRON SHEET FOR LOCATION OF CODE NUMBER.

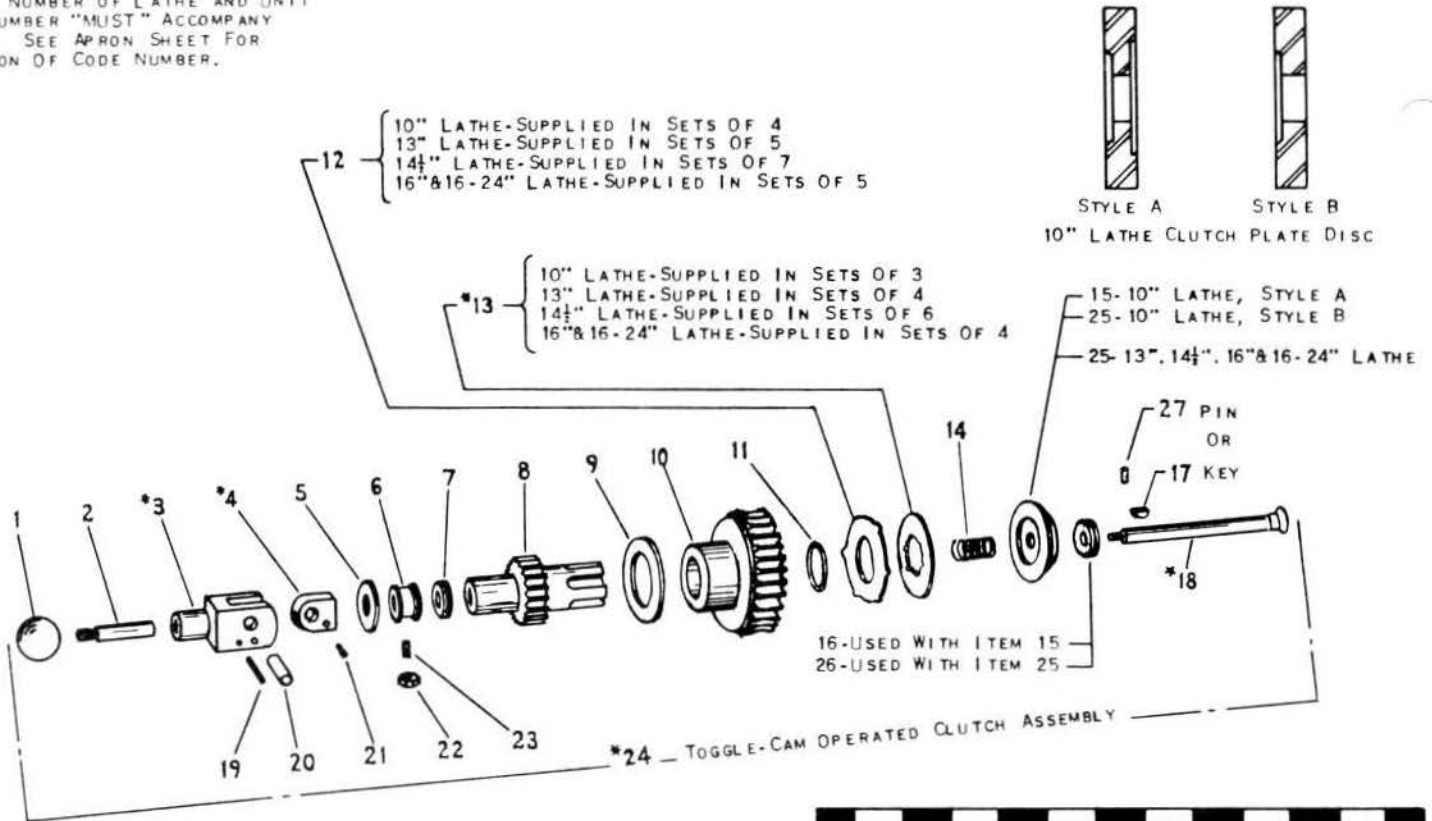

\*AVAILABLE ONLY AS SUB-ASSEMBLY. PARTS INCLUDED ARE INDICATED BY THE ITEM NUMBERS APPEARING IN PARENTHESIS AFTER PART NAME.

**APRON TOGGLE-CAM OPERATED CLUTCH**  
FOR 10", 13", 14 1/2", 16" AND 16-24" LATHES

ITEM NO.	PART NAME	10"		13"		14- 1/2"		16" & 16-24"	
		PART NO.		PART NO.		PART NO.		PART NO.	
1	FEED ROD KNOB	PT406K&FH1		PT406K&FH1		PT406K&FH1		PT406K&FH1	
2	HANDLE	PT46 24R1		PT46 24TH1		PT46 24TH1		PT46 24TH1	
3	BINDER CAM (19)	*AS46 22RH1		*AS46 22RH1		*AS46 22RH1		*AS46 22RH1	
4	SWIVEL NUT (21)	*AS46 23R1		*AS46 23TH1		*AS46 23TH1		*AS46 23TH1	
5	THRUST WASHER	PT46 25R1		PT46 25TF1		PT46 25TF1		PT46 25H1	
6	RETAINER BUSHING	PT46 26R1		PT46 26T1		PT46 26F1		PT46 26H1	
7	BEARING	AS8 41R1		AS8 41T2		AS8 41T2		AS8 41H2	
8	CLUTCH SLEEVE	PT46 20R1		PT46 20T1		PT46 20F1		PT46 20H1	
9	OIL DISTRI. WASHER	161 x 59		161 x 60		161 x 69		161 x 61	
10	WORM GEAR	PT77R1		PT77T1		PT77F1		PT77H1	
11	LOCK RING	PT408R1		PT408TF1		PT408TF1		PT408H1	
12	ORDER ITEM 13	AS411R1		AS411T1		AS411F1		AS411H1	
13	CLUTCH PLATES (12) PRICE PER SET	*AS410R1		*AS410T1		*AS410F1		*AS410H1	
14	SPRING	162 x 51		162 x 15		162 x 15		162 x 37	
15	CLUTCH PLATE DISC	PT46 28R1							
16	BEARING	ASA46 29R1							
17	KEY	PT46 31-1		PT2070-1		PT2070-1		PT2070-1	
18	CLUTCH DRAW BAR (27)	*AS46 21R2		*AS46 21T2		*AS46 21F2		*AS46 21H2	
19	PIN	160 x 33		160 x 33		160 x 33		160 x 33	
20	PIN	160 x 252		160 x 252		160 x 252		160 x 252	
21	CAP SCREW	114 x 708		114x 708		114 x 708		114 x 708	
22	HEX. NUT	138 x 17		138 x 17		138 x 17		138 x 17	
23	SET SCREW	120 x 908		120 x 908		120 x 908		120 x 908	
24	CLUTCH SLEEVE ASSEMBLY (1-2-3-4-5-6-7-8-9-10-11-13-14-18-20-22-23-25-26)	*AXS46 20R1		*AXS46 20T1		*AXS46 20F1		*AXS46 20H1	
25	CLUTCH PLATE DISC	PT46 28R2		PT46 28TF1		PT46 28TF1		PT46 28H1	
26	BEARING	AS1A46 29R1		AS1A46 29TH1		AS1A46 29TH1		AS1A46 29TH1	
27	PIN	160 x 18		160 x 18		160 x 18		160 x 18	